

Bipolaire Microstep Driver
MSD-32-2.5

Specifications:

Power Supply

Minimum Voltage : 10 Vdc
Maximum Voltage : 32 Vdc

Microsteps

Minimum number of microsteps : 1
Maximum number of microsteps : 8

Number of Phases : 2

Steppermotor

Minimum Phase Current : 0.4 A
Maximum Phase Current : 2.5 A

Number of motorwires (2 phase) : 4, 6, 8

Optocouplers :

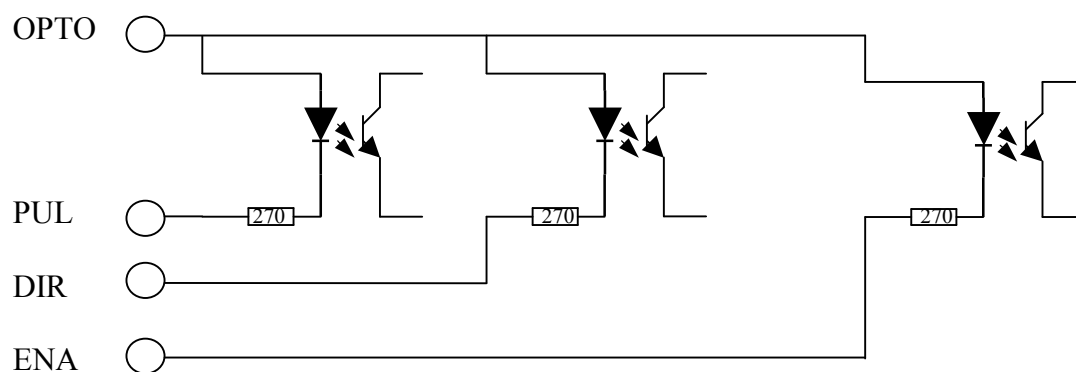

Signals microstapdriver

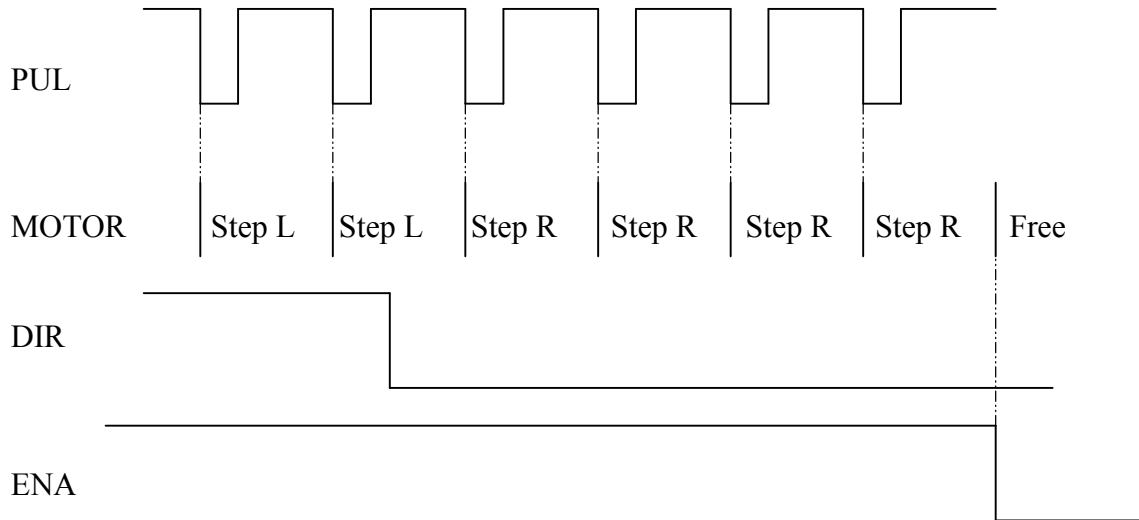

Min puls high time 5 uS
 Min puls low time 5 uS
 DIR to PUL lead time 5 uS
 ENA to PUL lead time 5 uS

Dipswitches

S5,S6	microsteps	Step	Step / Rotation
1 1	1	1.8°	200
0 1	2	0.9°	400
1 0	4	0.45°	800
0 0	8	0.225°	1600

S4 = 1: No current reduction

S4 = 0 : Auto current reduction. 200 mS after the last puls the current is reduced to 60%.

This is to reduce the heat dissipated.

S1 S2 S3	Current	S1,S2,S3	Current
0 1 1	0.4 A	0 1 0	1.8 A
1 0 1	0.7 A	1 0 0	2.1 A
0 0 1	1.1 A	0 0 0	2.5 A
1 1 0	1.4 A		

0 = Off

1 = On

Connections

OPTO	: + 5 V
PUL	: STEP
DIR	: DIRECTION
ENA	: SWITCH (optional)
+ V	: Positive of Power Supply
GND	: Negative of Power Supply (or ground)
A+	: A connection of 1 phase of stepper motor
A-	: A\ connection of 1 phase of stepper motor
B+	: B connection of 2 phase of stepper motor
B-	: B\ connection of 2 phase of stepper motor

Standard Connections (Example)

X-axes

OPTO	: + 5 V (computer)
PUL	: LPT - 2
DIR	: LPT - 3
ENA	: NC

Y-axes

OPTO	: + 5 V (computer)
PUL	: LPT - 4
DIR	: LPT - 5
ENA	: NC

Z-axes

OPTO	: + 5 V (computer)
PUL	: LPT - 6
DIR	: LPT - 7
ENA	: NC

Connection example COMPUTER

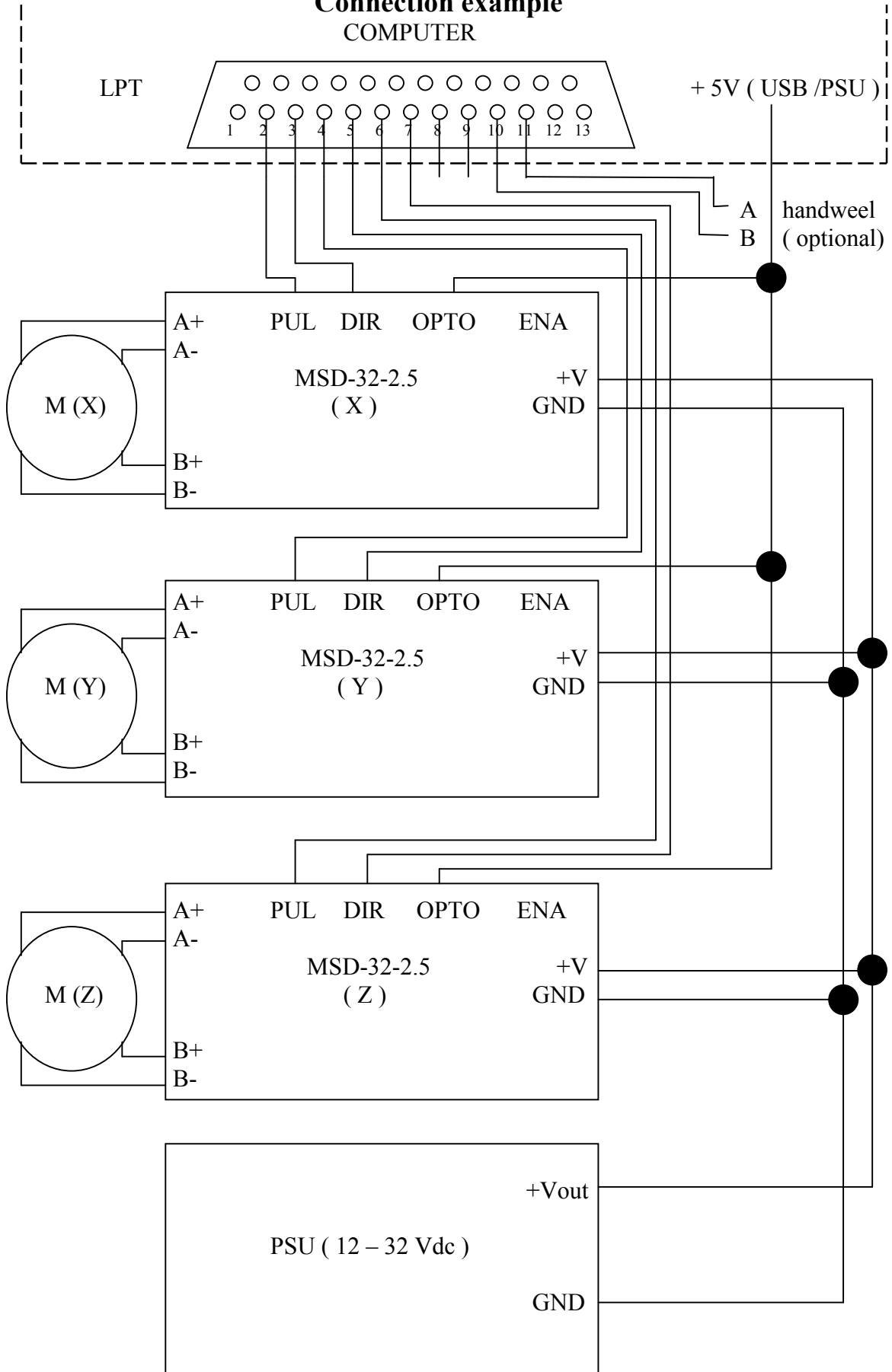

4 Wire 2 phase steppermotor

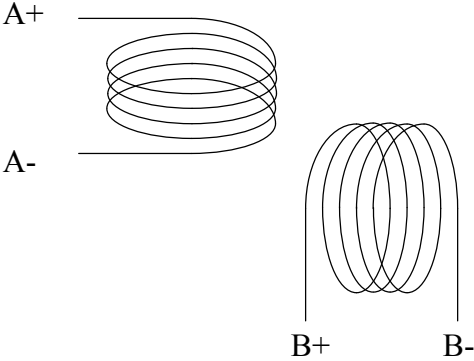

6 Wire 2 phase steppermotor

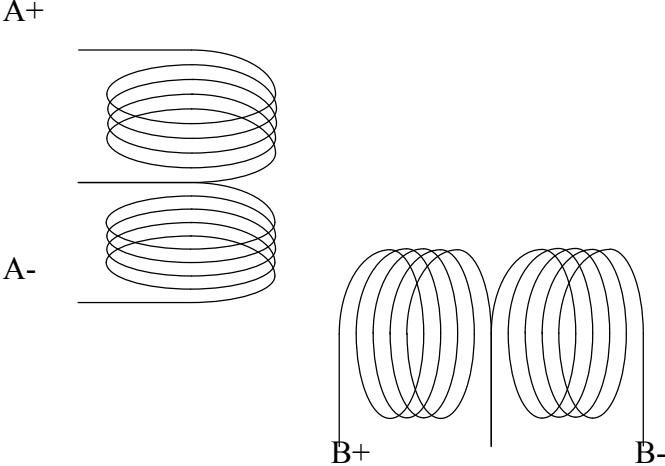

**8 Wire 2 phase steppermotor
Parallel connected**

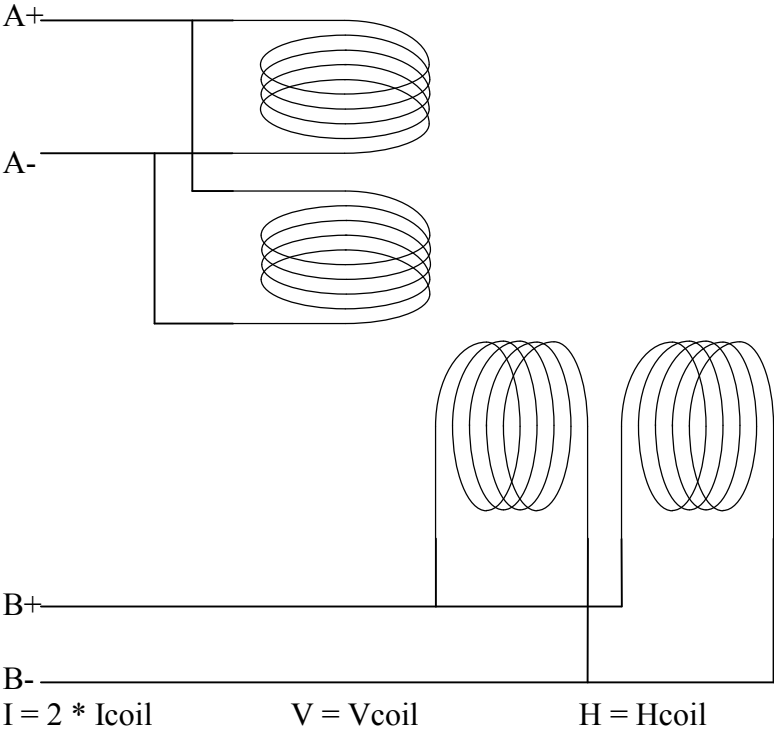

**8 Wire 2 phase steppermotor
Serial connected**

